

Product body / part name

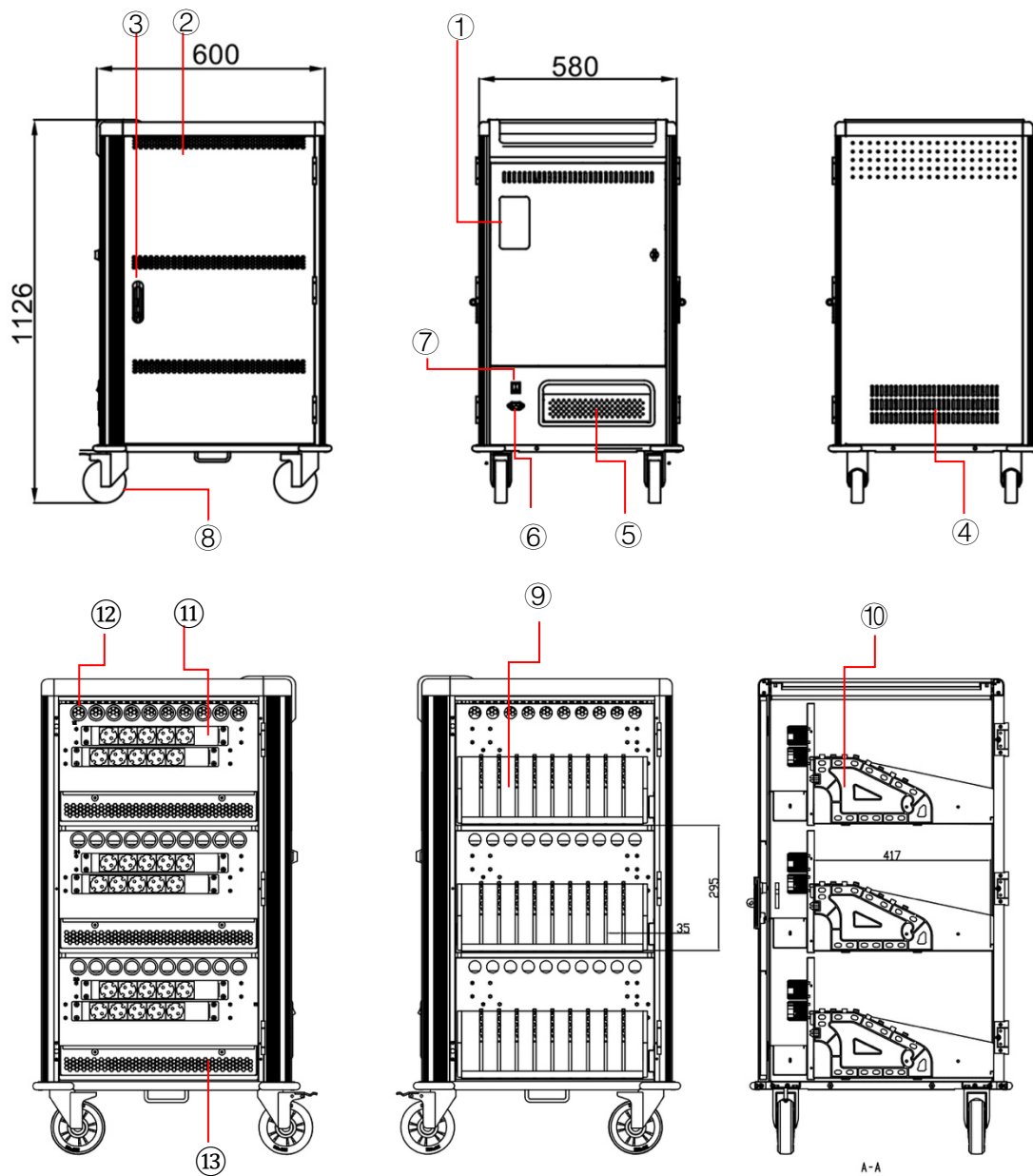

- ① Door
- ② Lock
- ③ Castor
- ④ LED indicator
- ⑤ Power switch
- ⑥ Power socket
- ⑦ Power cable storage
- ⑧ Vent
- ⑨ Individual outlet
- ⑩ PDU socket
- ⑪ Adaptor storage
- ⑫ Devices storage
- ⑬ Divider

## Charging operation instruction

1. Power off the charging cart, open the front door

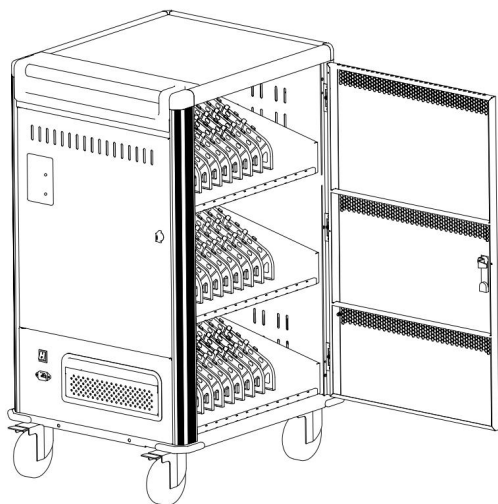

2. Put in the devices numbered in the slot one by one

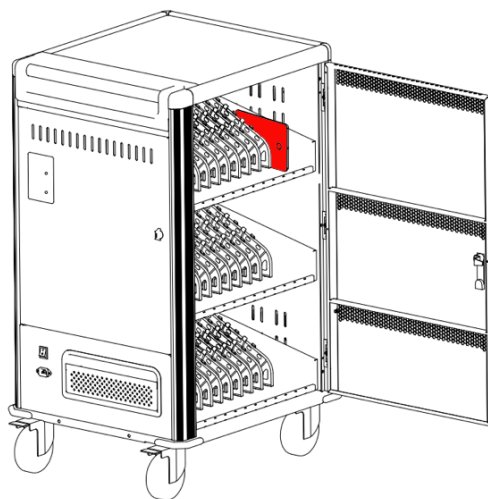

3. Insert the charging cable to each device

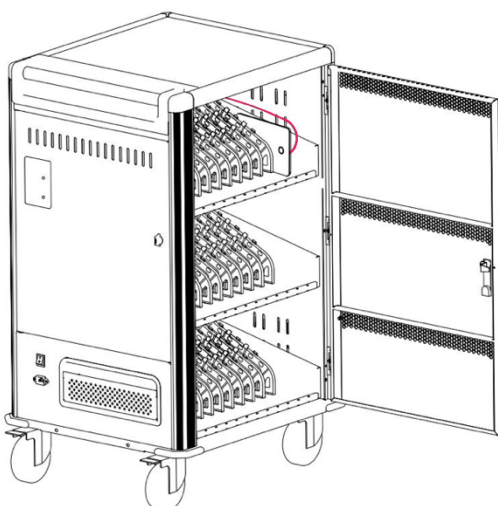

4. Connect the input plug to the wall socket ,then lock the door

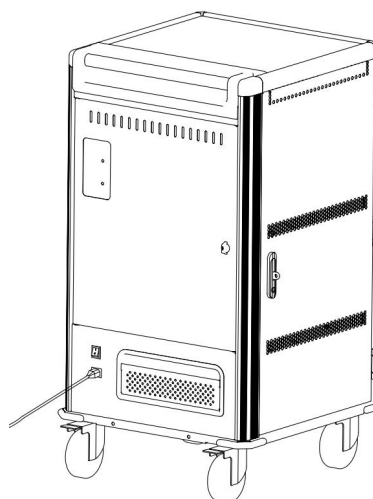

5. Turn on the power switch to start charging ,the led indicates red color to show the device in charging ,then the device full charged, the led turn to green color .

Specification	
Cart dimensions (W x H x D) and weight	600*580*1126mm/78kg
Packing dimensions (W x H x D) and weight	645*620*1272mm/93kg
Input Voltage	AC230V 50Hz 15A
Output Voltage	AC230V 50Hz 15A
Charging System	Bank sensor Intelligent charging system
Storage/charging capacity	30bays 15.6inch
Cooling system	/
Castor	4 (2 normal, 2 with breaker)
Control protection	- Independent circuit overload protection - Intelligent current overload shunt
LED indicator	2 LED lights represent 1/2 zone Red: the zone is working Off: the zone is not working
Working environment	Temperature: -10~40°C Humidity: 20~80%
Certificate	CE, UKCA, RoHS

Components	
Cart	1
Manual	1
Power Cord	1 (3m)
Key (front and rear door)	4
Key (electric storage)	2
Main body fixing plate, main body side screw fixing ※Connect with wooden base for transportation	2

## Handling Precautions (Be sure to read)

### warning

- Do not disassemble, repair, process or modify this product.
- Do not apply strong vibration, shock, or excessive force to this product.
- Do not use or store this product in a place exposed to water or underwater.
- Do not touch this product with wet hands.
- This product is powered by electricity and may catch fire. If smoke or a strange odor comes out, turn off the power of this product and the connected tablet device, and contact the store where you purchased the product or us.
- Do not use this product above 2,000m from sea level.

### Note

- Our company shall not be liable for any direct or indirect damage caused by the failure of this product or its use.  
Please note.
- We do not guarantee any damage, loss, or other troubles of data or programs that occur while using this product.
- Please use this product indoors only
- Do not store or store this product in an unstable place.
- When cleaning this product, do not use anything that contains volatile organic solvents such as benzene and thinner.
- Be sure to turn off the power of this product when connecting to an outlet with a power cord.
- Do not connect using an extension cord or power strip. Please plug it directly into a wall outlet.
- Please close the door of this product during use.
- Do not place heavy objects such as TVs and displays on this product.
- Do not use a damaged cable.
- When connecting or disconnecting the cable of this product or other equipment, be sure to hold the connector and do not apply excessive force.
- Be sure to turn off the power of this product when inserting or removing the tablet.
- Make sure that the tablet is turned off before connecting to this product.
- When moving this product, be sure to disconnect the power cord from the outlet.
- Move this product slowly.
- Lock the caster stopper when not moving.
- Do not charge or connect devices other than tablets.
- Do not unplug this product from the wall outlet when the operator's hands are wet.
- This product is not intended to be operated by children. Only adults should operate this product.
- Do not allow this product to get wet.
- Do not block the vents so as not to interfere with air circulation.
- Do not block the vent when charging.

### Caution

- The rack may tip over cause serious personal injury Before extending the rack to the installation position, please read the installation instructions.
- Do not place any stress on the slide-rail mounted equipment of the installation position.
- Do not leave the slide-rail mounted equipment in the installation position.